

Pressure Measurements: Tank Efflux & Implosion of a 2-L Soda Bottle

Process Engineering Measurements - Week 3

Robert P. Hesketh, Stephanie Farrell and C. Stewart Slater
Chemical Engineering
Rowan College of Engineering

Laboratory Notebook

A laboratory notebook must be used to record data for each experiment. All information should be written directly into the laboratory notebook in ink. Attach one copy of the data from the team laboratory recorder's notebook pages. The minimum amount of information required for the laboratory notebook will be given in each experiment. Submit one set of yellow pages from each team. Submit the data analysis as homework in 1 week's time. One report per team.

Pressure Measurement: Tank Efflux Experiment

Objectives

1. Determine the absolute pressure at the bottom of a 28 inch column of water. Give your answer in Pascals.
2. Understand the accuracy limitations of a low pressure diaphragm gauge.
3. Compare the accuracy of a Bourdon pressure gauge and a PX162 pressure transducer.
4. Explain the difference between gauge and absolute pressure to a high school student.
5. Perform unit conversions of pressure and flowrate.
6. Calibrate a pressure transducer.
7. Set-up and run an experiment in which pressure is measured and recorded as a function of time using DaqView. Plot the data using Excel. Determine the equation which gives the best fit to a line.

Introduction

Tanks and vessels are used extensively in the process industry for both batch and continuous processes. At the start-up or shut down of any process, tanks must be filled or emptied. Batch processes require that every tank be filled and drained for each *batch* of chemicals produced. Batch processes are used for mixing, reaction, and separation of liquid and solid mixtures. Tanks are also employed to store chemicals prior to adding them to various stages in a production operation as well as to store the finished product before packaging. Many industries use batch processes such as the pharmaceutical and food and beverage industries. For example, what would Anheuser-Busch's Budweiser be without its beechwood aging tanks for beer production? (see their home page <http://www.budweiser.com/making.html>). Other common examples of batch tank drainage include the emptying of hoppers containing solids, minerals and grain, and the discharging of reaction tanks and storage tanks.

In this experiment you will drain a tank of water and measure pressure and liquid level to determine the rate of tank drainage as a function of hydrostatic pressure and time. A spreadsheet will be used to analyze the data to determine instantaneous flowrate and plot pressure and flow as a function of elapsed time. This experiment will reinforce the previous *hydrostatic pressure experiments* which introduced pressure and the relationship $P = \rho gh$. To review these concepts refer to the handout from *Felder and Rousseau, Chapter 3*.

Theory

The absolute pressure resulting from a column of fluid of height h_m is represented by

$$P = P_o + \rho gh_m$$

Where P_o is the pressure at the top liquid surface of the tank, which when open to the atmosphere is equal to barometric pressure, ρ is the density of fluid, g is the acceleration due to gravity and h_m is the height of fluid from the top surface of the liquid to the point at which pressure is being measured. Atmospheric pressure changes slightly from day-to-day; some typical values are 1.03 atm (atmosphere), 29.7 in. Hg, 75.2 cm Hg, or 100.1 kPa. The process simulation package HYSYS assumes that atmospheric pressure is exactly one atmosphere (1 atm) or 14.696 psia.

A pressure measuring device or dial gauge typically measures in *gauge* pressure which is the pressure measured relative to the *atmospheric* pressure. A gauge pressure of zero means that the *absolute* pressure is equal to atmospheric pressure. The following equation shows the relationship between gauge and absolute pressure

$$P_{absolute} = P_{gauge} + P_{atmospheric}$$

or using abbreviations

$$P_{abs} = P_g + P_{atm}$$

Since measurement devices report gauge pressure, then results from experiments are typically reported using gauge pressure. The abbreviations psia and psig are commonly used to denote lb_f/in^2 in absolute and gauge, respectively.

psig – pounds per square inch gauge
psia – pounds per square inch absolute

The process flow in tank drainage can be represented by an unsteady state mass balance

$$\frac{dm_{\text{tank}}}{dt} = \frac{d(\rho A_{\text{tank}} h)}{dt} = -\dot{m}_{\text{out}}$$

The mass flow out of the tank is a complex function of the liquid height above the outlet of the drainage tube and the pressure losses caused by fluid flow through the tank, tubing and fittings. These aspects of fluid flow will be covered in subsequent courses. The solution to the above equation assuming no pressure losses in the system is:

$$h_{\text{initial}}^{0.5} - h^{0.5} = \frac{A_{\text{drain}}}{A_{\text{tank}}} \left(\frac{g}{2} \right)^{0.5} t$$

where

h height of fluid above the tank drain pipe exit ($h = h_m + h_{\text{drain}}$)

h_{initial} initial height of fluid above tank drain pipe exit

A_{drain} inside cross sectional area of drain pipe

A_{tank} inside cross sectional area of tank

g 9.81 m/s^2

t time in minutes

The assumption of no pressure losses in the system is equivalent to saying that there is no friction. We all know this is not true! The question for engineers is, how significant is the effect of friction of liquid flowing out of a tank and through pipes, fittings and valves? You will answer this question in this experiment. Also please note that the height of liquid in the above equation is the height of liquid in the tank that is measured, h_m , plus the height of liquid from the measurement point to the exit of the drain tube, h_{drain} . $h = h_m + h_{\text{drain}}$

Measurement Equipment

In the tank efflux experiments you will use 3 devices to measure the hydrostatic pressure in the 30 gallon tanks: sight gauge, low pressure diaphragm, and a pressure transducer.

Sight Gauge The first device is a simple sight gauge with a metal rule. Using the principle that a continuous fluid has the same pressure at equal vertical heights, then the sight gauge will show the level of liquid in the tank. The accuracy of this device is dependent on the quality of the metal rule behind the clear plastic tubing. For example, was the printing and stamping of the numbers and lines on the rule compared to a National Institute of Standards and Technology (NIST) standard? Or was the metal rule bent or has it expanded from thermal or mechanical forces? The precision of this device is dependent on the smallest scale division of the rule. As in the case of the graduated cylinder you should be able to divide the space between a division by thirds. An example of the precision of this device would be if 10 people correctly read a liquid height, what would be the largest difference in values?

Pressure gauge - Bourdon: You will use a Bourdon type vacuum pressure gauge from the Marsh Instrument company \$32. This gauge has a range up to a vacuum of 30 inches of mercury (in. Hg). The accuracy of this gauge is a standard ANSI Grade B: 3-2-3%. The middle range of the scale has the highest accuracy of $\pm 2\%$ of the full scale reading and the lower and upper ends of the scale have a lower accuracy of $\pm 3\%$ of the full scale reading. For example the full scale reading is 30 inches of Hg vacuum. Then a reading of 15 in. Hg will have an uncertainty of ± 0.6 inches of mercury.

Pressure gauge - diaphragm: The low pressure diaphragm gauge from the Marsh Instrument company \$57. This gauge has a range from 0 to 35 inches of water. The low pressure diaphragm gauge has an accuracy of $\pm 2\%$ of the full scale

reading. For example the full scale reading is 35 inches of water. Then any reading will have an uncertainty of ± 0.7 inches of water.

Pressure transducer: You will be using an Omega Instruments PX242-005G5V pressure transducer \$138. This transducer has a range of 0-5 psig (1psi = 27.68 in H₂O). If this gauge is subjected to more than 20 psig then it will be ruined (overpressure). The accuracy of the pressure transducer will be determined from your calibration curve. You will calibrate the voltage output with the height of liquid in the tank. Your next task is to determine if a plot of liquid height vs. voltage is linear. The manufacturer claims that all of the points are within $\pm 1.5\%$ of full scale reading. The resolution of this transducer is determined from the number of bits on the card. A 12 bit Daqboard card is resolvable into $2^{12} = 4096$ steps. Since we are using a unipolar scale from 0 to 10 V and the output of the transducer is 1 to 6 V, then we are only using 1/2 of 4096 bits. Thus our 5V range can be resolved using 2048 steps. This corresponds to a resolution of the pressure scale range of 0-5 psig of 2.44×10^{-3} psi/step (5 psi/2048 steps) or 1 psig can be divided into 410 divisions. This is a tremendous resolution compared to the resolution of the other pressure measurement devices. For placing error bars on your graphs use the value of linearity: $\pm 1.5\%$ of full scale or ± 0.075 psig or 0.141 in. H₂O.

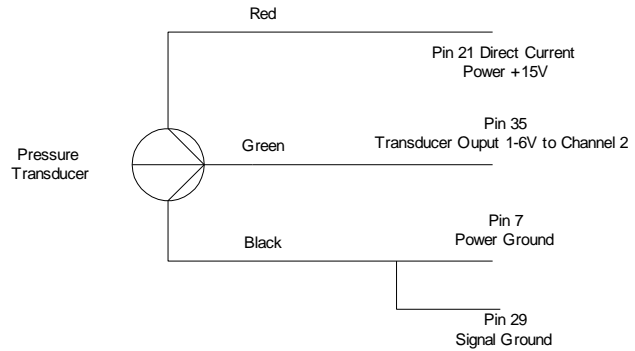

Figure 1: Pressure Transducer

Experimental Materials and Methods

The experiment will use a 30 gallon high-density polyethylene (HDPE) tank fitted with a piping manifold and pressure gauge and pressure transducer. The tank is filled with water. No hazardous materials will be utilized in this experiment. There are no unsafe operating conditions such as pressure or temperature. Standard PPE such as eye protection must be worn.

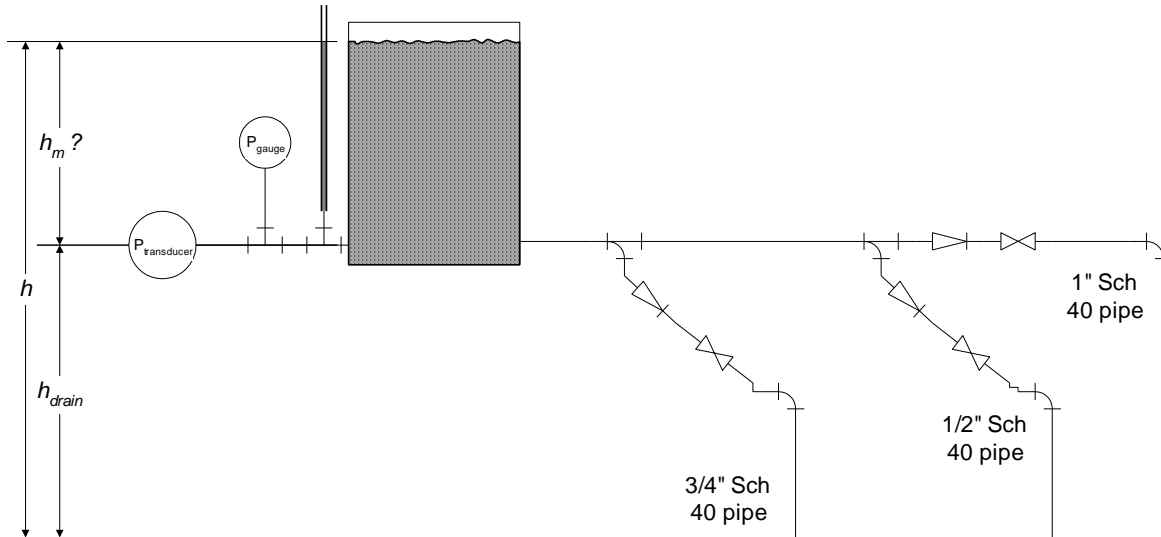

Figure 2: Tank Drainage Apparatus

Laboratory Notebook (Do boldface sentence before class.)

1. Label a new page in the laboratory notebook. (One set of yellow pages will be turned in at the end of the laboratory period.) Title this experiment. Enter your name and your group names and date at the top of the page. Write a brief description of this experiment
2. Draw a sketch of the experimental apparatus. Show the dimensions measured in steps 3 and 4 on figure.
3. Measure the vertical distance from the center of the exit tube outlet to the bottom of the tank.
4. Measure the tank inside diameter.
5. Record the name of the data file (Excel file)
6. Record the barometric pressure.

Experimental Procedure

1. Review the procedure and safety analysis with your instructor.
2. Inspect the tank to make sure the tank is nearly empty, the valve is shut and the gauge reads zero.
3. Configure the data acquisition system to record the pressure as a function of time using the PX242-005G5V pressure transducer. Set the Device, Configure Hardware Settings Analog Input Option Cards: P1 Channel →0 to Direct Signal Connection (DBK 11A card). Next set up the configuration window to give the results shown in given in Table 1. Use an averaging of 100 for all of the runs. Test the circuit by pressing the black triangle (▶) and checking for a voltage reading next to channel two.
4. Calibrate Pressure Transducer
 - 4.1. Fill the tank with water until the water level is visible in the sight gauge.
 - 4.2. Use the metal rule and clear plastic tubing to read the height of water and record pressure transducer output reading from DaqView visual display screen into the laboratory notebook. The zero of the water height should correspond to the value of h_m shown in Figure 2. Remember that when you plot your data and compare it with theory you will need the total liquid height in the tank and the pipe $h = h_m + h_{drain}$. As you are calibrating your pressure transducer also record the low pressure diaphragm gauge readings. Comment on the difference between the sight gauge (metal rule and clear plastic tubing) and low pressure diaphragm gauge.
 - 4.3. Repeat for approximately 8 measurements and stop recording data when the water level reaches 30 gallons.
 - 4.4. Make a plot of the height of water on the y-axis and the output voltage on the x-axis.
 - 4.5. Fit a linear trendline through the data. This is your calibration curve to convert voltage to height of liquid in tank.
5. Prepare the tank for a run. You will be conducting 3 experiments: (the order will be given by professor)

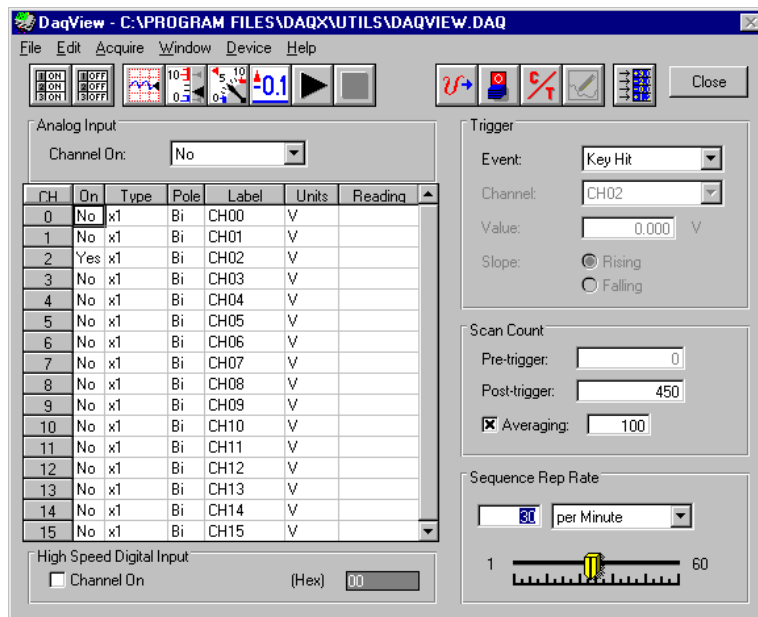

Figure 3 Configuration for 0.5 inch ID drain tube

Table 1: Experimental Software Setup

Experimental Run	Post-trigger	Sequence Rep Rate
1 inch drain tube	300	1 per second
0.75 inch drain tube	600	1 per second
0.5 inch drain tube	450	30 per minute

6. Experimental Run:
 - 6.1. Make sure the drain hose is connected to the tank and the outlet is in a drain.
 - 6.2. Simultaneously open the valve at the bottom of the tank and start the data acquisition system.
 - 6.3. Once the tank has drained to the 10 gallon mark stop the data acquisition process by clicking on the cancel button and close the valve on the drain.
7. Start filling the tank for the next 2 runs and repeat the experiment with a new drain tube.

Work to be turned in (All work is to be done in teams. Submit one per group.)At end of laboratory period hand in yellow page from laboratory notebook. Include names of group members who participated in the experiment. Homework (also a group assignment) is due one week from today.

- 1) Printout **three graphs** as described below. Sample calculations must be given for all equations entered into the spreadsheet - show units in these equations.
 - a) **Calibration curve plot:** Plot the calibration curve and regression (trendline) for the pressure transducer. The y-axis of this plot should be height of water and the x-axis should be voltage output. Report the regression with units for both constants on the plot and on the engineering paper sample calculations.
 - b) **Liquid height (calculated from pressure transducer readings) as a function of operating time plot** for all three runs by doing the following (see example spreadsheet given below):
 - i) Prepare a spreadsheet that has entries for the laboratory. Remember to input units in the column headings of the spreadsheet.
 - ii) Convert the pressure transducer voltage output readings to height of water above the pressure transducer, h_m , using the calibration curve obtained above.
 - iii) Plot total liquid height, $h = h_m + h_{drain}$, as a function of operating time for each run. Determine the best trendline for each run. You may need to use a polynomial etc.!
 - iv) Place all three curves on one plot. Use the commands Chart, Source Data, Series, Add, X values, Y values to add the three curves to one plot.
 - c) **Comparison with theory plot.** Compare the experimental pressure transducer runs with the theory presented earlier by doing the following:
 - i) Make a plot of $h_{initial}^{0.5} - h^{0.5}$ vs. time and fit a linear trendline through the data. Remember that the liquid height is defined by the equation: $h = h_m + h_{drain}$ (refer to Figure 2). When you fit the trendline to the data remember to specify an intercept of zero. The trendline will give you the slope from your experimental data
 - ii) Calculate the theoretical slope as given by: $Slope = \frac{A_{drain}}{A_{tank}} \left(\frac{g}{2} \right)^{0.5}$

The areas of the drain and the tank can be calculated from their diameters.
 - iii) Compare the values of the slopes and speculate on the difference between the slope obtained from the experiment and the theoretical slope. See the introductory text given above on the effect of friction.
 - d) Comment on the difference between the low pressure diaphragm gauge readings, pressure transducer readings and the sight gauge readings. Why are they different? What is the difference in height between the readings?

Summary: Your homework should consist of 3 plots, sample calculations and answers to the above questions.

Calibration Curve for pressure transducer

Tank drainage height plot (3 curves – one for each drain)

Tank drainage comparison to theory plot (3 curves – one for each drain)

Example Spreadsheet:

	A	B	C	D	E
3	Time (s)	Voltage (V)	height above transducer, h_m , (in)	height above drain tube, h , (in)	$h_{mi}^{0.5} - h^{0.5}$ (in ^{0.5})
4	0.00	3.528	25.76	33.26	0.0000
5	2.00	3.524	25.71	33.21	0.0049
6	4.00	3.517	25.60	33.10	0.0139

Corresponding equations for this spreadsheet are given in the table below: (These can be seen by clicking on each individual cell or Tools, Options, View tab, and click on formulas.)

	A	B	C	D	E
3	Time (s)	Voltage (V)	height above transducer, h_m , (in)	height above drain tube, h , (in)	$h_{mi}^{0.5} - h^{0.5}$ (in ^{0.5})
4	0	3.528	=14.38*B4-24.97	=+C4+6+1.5	=+\$D\$4^0.5-D4^0.5
5	2	3.524	=14.38*B5-24.97	=+C5+6+1.5	=+\$D\$4^0.5-D5^0.5
6	4	3.517	=14.38*B6-24.97	=+C6+6+1.5	=+\$D\$4^0.5-D6^0.5

Notice that the height, h_m , is measured from the center of the pressure transducer outlet to the liquid height in the tank. The value of the total liquid height, h , is calculated as the sum of the distance of the pressure transducer outlet above the table surface, 1.5 in, and the distance from the table top to the drain outlet, 6 in. **Please note you will have different numbers than given in this example.**

Vacuum Pressure Measurement

or

Implosion of a 2-L Soda Bottle

Objectives

1. Understand the concept of vacuum
2. Know the difference between vacuum pressure and gauge pressure

Introduction

Several important processes operate under a vacuum. The *Drainage of a Batch Process* experiment has a positive pressure exerted at the bottom of the tank. A vacuum is a “negative” pressure or one that is below atmospheric. Space is the perfect vacuum. Some processes operate under vacuum conditions so that they may perform reactions or separations more effectively. Not to much unlike a common household vacuum cleaner, solids are typically conveyed from one point in a process to the other using a vacuum. Certain food products are vacuum packed to improve freshness such as ground coffee to retain it flavor!

This experiment will demonstrate vacuum pressure and measurements using a plastic soda bottle which will be imploded.

Theory

Absolute pressures less than atmospheric (1 atmosphere) are considered vacuum pressures. They can be considered a “negative” gauge pressure or a “positive” value of vacuum. For example a gauge pressure of -1 cm Hg (75.0 cm Hg absolute) may also be called 1 cm Hg of vacuum. The lowest pressure that can be obtained is 0 cm Hg absolute. This is known as a perfect vacuum.

Experimental Materials and Methods

The experiment will take place using a sink-mounted vacuum aspirator. The soda bottle utilized will be a standard 2-L PTFE, (polyethylene terephthalate) bottle. There are no unsafe operating conditions such as pressure or temperature. Note: the imploded bottle serves as its own safety relief mechanism. Standard PPE such as eye protection must be worn.

Experimental Procedure

1. Review the procedure and safety analysis with your instructor.
2. Install an uncollapsed 2-L soda bottle on to the aspirator device attached to the sink faucet.
3. Turn on water at the full flow rate.
4. Watch the vacuum gauge and the soda bottle and when the walls completely collapse (come together) record the pressure (in Hg of vacuum).
5. Turn off water and slowly remove stopper.
6. Repeat the process at a slower flowrate of water.
7. **Record the barometric pressure in the room**

Results to be Reported. 1 homework set per team.

1. Report the approximate vacuum pressure (in Hg of vacuum) it took to completely collapse the soda bottle.
2. Convert your value to
 - a. in. Hg (gauge)
 - b) in. H₂O gauge
 - c) in. Hg absolute
 - d) kPa (gauge)
 - e) kPa absolute

For conversion to absolute pressure units use the actual barometric pressure the day you performed the experiment.