

The process and instrumentation diagram for the Hampden Fluid Flow Bench shown Figure 1.

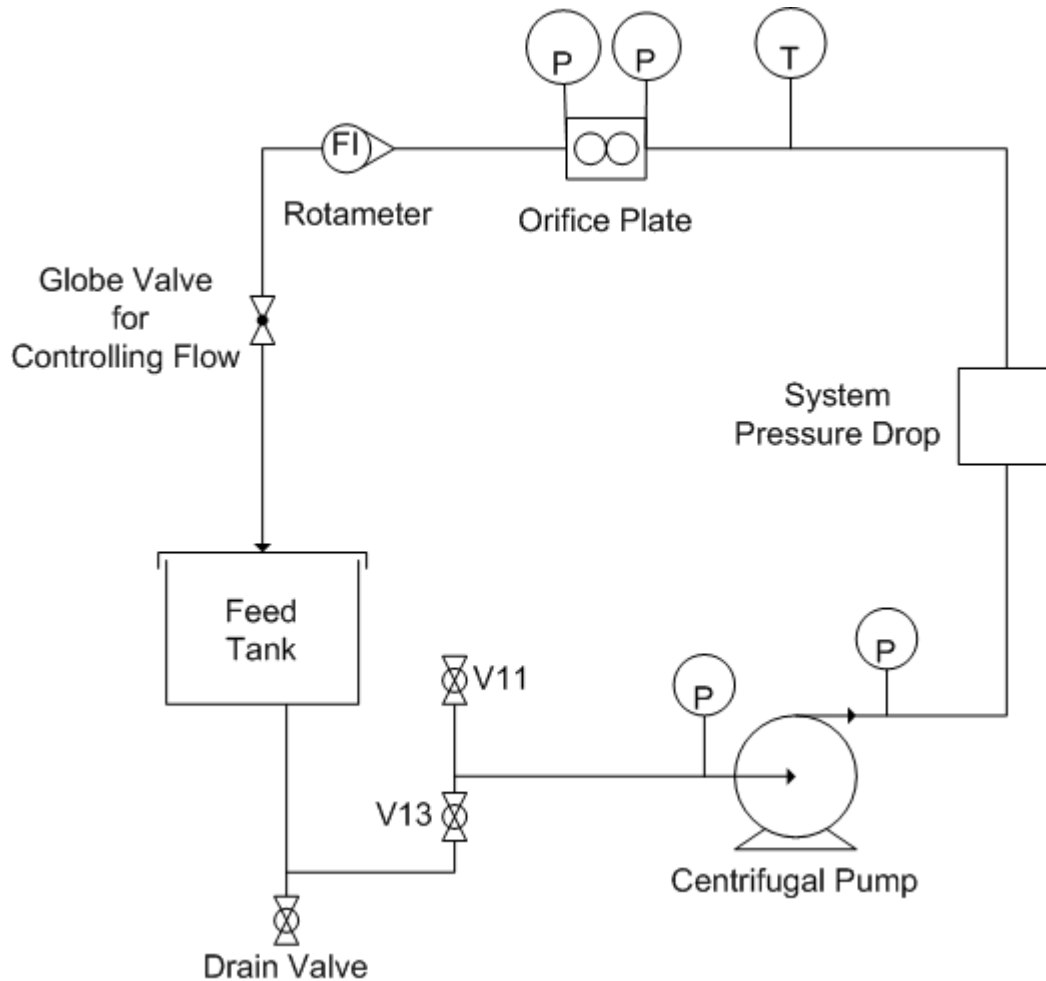

Figure 1: Process and Instrumentation Diagram (P&ID) for Price Centrifugal Pump Experiments

Characteristic Pump Curve Experiment:

Procedure for Team

1. Check and fill if necessary the water tank until at least 2/3 full.
2. Open all valves and run pump to remove any air in the pipes and fittings.
3. Turn pump off.
4. Close all valves.
5. Use the rotameter and orifice plate meter. Record the orifice plate hole size which is located on the exposed tab of the plate. Also record the voltage and amperage of the pump. (Both 115V and 240V are given – use the appropriate value). This will be used to compare with the actual measured value.

6. Write the following labels for a data table on a separate page in your laboratory notebook as well as in a spreadsheet of a laboratory computer (always record the data in your notebook in pen before entering it into the computer):

Run	Nominal Rotameter Flowrate (GPM) ¹	Pump Inlet Pressure (cm H ₂ O)	Pump Outlet Pressure (psig)	Inlet Orifice Pressure (Dial Gauge) (psig) ¹	Outlet Orifice Pressure (Dial Gauge) (psig) ¹	Temperature (°C)	Power (W)

7. Verify that the pressure indicating devices are connected to the orifice plate pressure taps.
8. Determine a flow path, and open appropriate valves so that the fluid will flow through the pump, flowmeters and return into the tank. (i.e. for the 3/8" line, open valves BV-1, BV-2, BV-3, BV-6, BV-13, and the globe valve). Close the main control valve.
9. Turn power on to unit at control panel. Turn transducers on.
10. Shut main control valve off, turn on the pump, and after 1 s open valve to obtain fluid flow. Look at rotameter float to see if you are turning the appropriate valve..
11. Select at least 15 flowrates in the range of the rotameter (0 – 10 GPM) and additional points to cover the extended flowrate of the orifice plate. You should have at least 15 points.
12. In your laboratory writeup you should give
 - a. Each team will construct two characteristic pump curves:
 - i. Standard Pump Plot showing pressure drop across the pump as a function of flowrate. Additionally, this curve should show efficiency as a separate line using the second y-axis.
 - ii. Pump Plot showing pressure drop across the pump as a function of flowrate. Additionally, this curve should show power delivered to the pump as a separate line using the second y-axis.
 - b. Your recorded data tables
 - c. Sample (hand) calculations of each calculated value
 - d. Suggestion for optimum operating conditions for this pump.
13. Give a brief description of the apparatus and procedure employed in the experiments
14. Write a few sentences summarizing what you learned from these experiments.

¹ Use calibration data to obtain actual flowrates

Calibration Data:

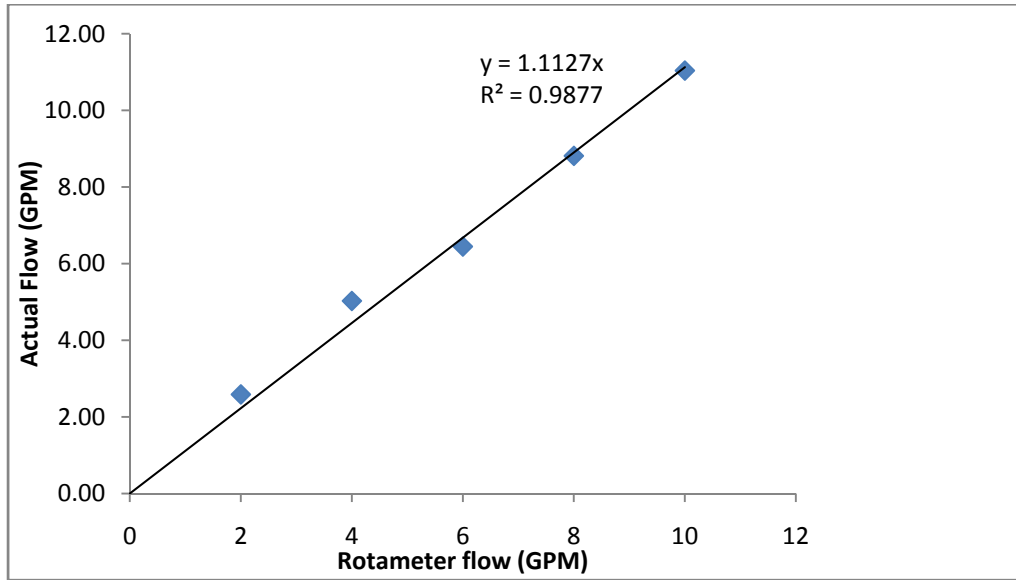

Figure 2: Calibration of Rotameter

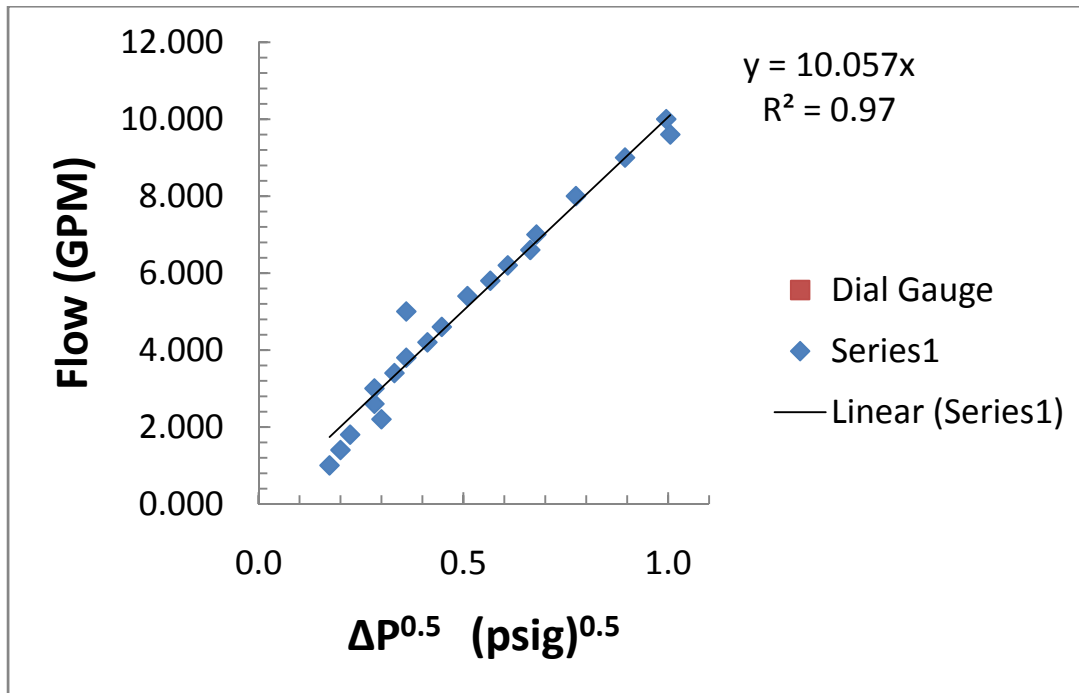

Figure 3: Calibration of Orifice Plate (0.655 in)