

Competitive Assessment of Maglite Flashlights

Assigned January 27 & 28, 2004

Submission Date: February 3 or 4, 2004

Purpose of Laboratory

Have you ever wondered how something works? An automobile? A pencil sharpener? A pepper grinder? How about a rocket, or a harmonica?

Have you ever had an idea for a way to improve on something that already exists? A more durable cell phone? An easier to hold controller for a video game? A better mousetrap? How about a flashlight?

Anthony Maglica had lots of ideas, and created a company based on those ideas in 1955. In the late 1970s, he developed a new style of improved flashlight which he called the "Maglite." The original Maglite used 2 or 3 'D-cell' batteries, and was designed for use by the public safety sector. It was a big commercial success. He continued to innovate and refine his designs, and a few years later introduced the "Mini-Maglite," which used 2 AA-cell batteries, as shown in Figure 1.

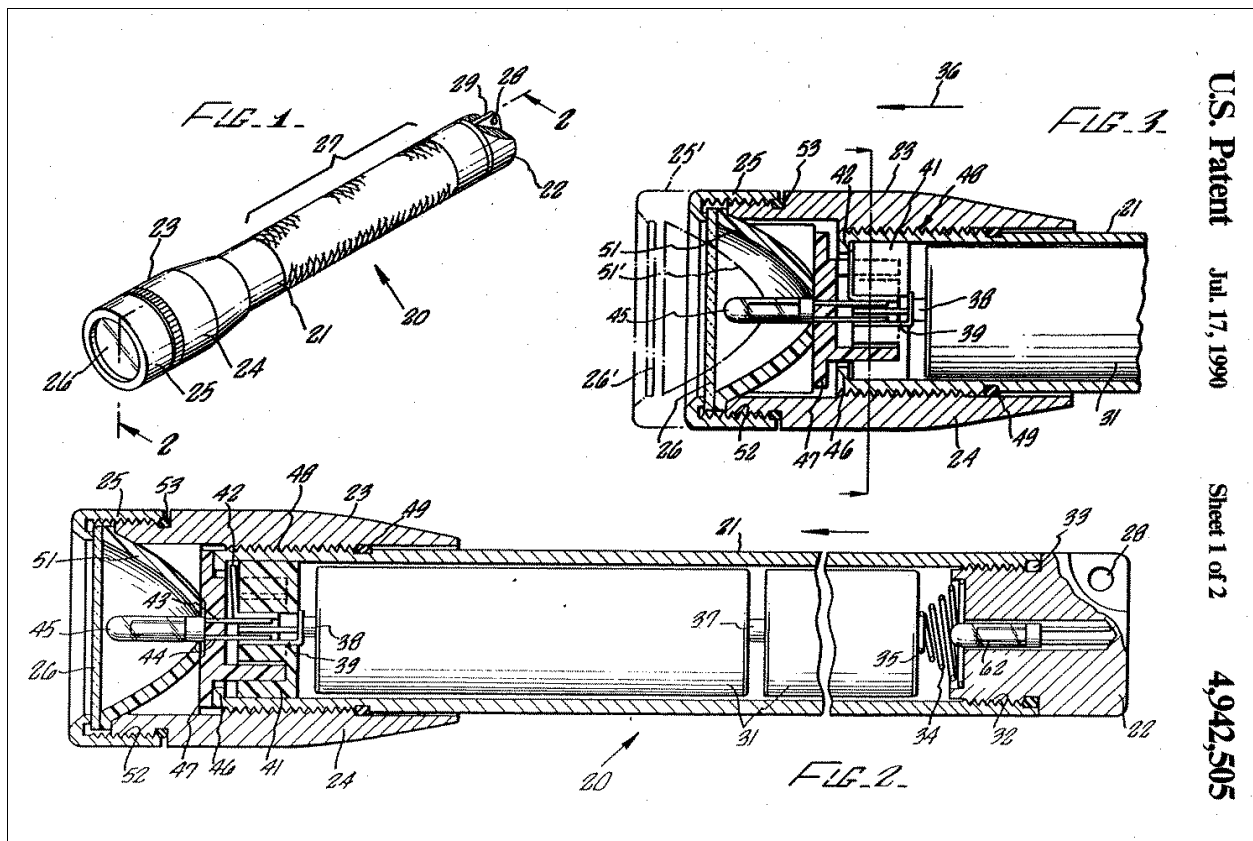

Figure 1: Illustrations from Anthony Maglica's 1990 patent for the Mini-Maglite.

U.S. Patent Jul. 17, 1990

Sheet 1 of 2

4,942,505

Part of the process of design engineering is understanding how things are made and put together. One way to gain this understanding is by taking something apart, and comparing it to another, similar product. This is one type of “*competitive assessment*.”

This laboratory will introduce you to the principles of competitive assessment. You will dissect a Maglite flashlight and determine how it works. You will also compare the Maglite flashlight design with that of another small flashlight. Suggested investigations for team members: electrical circuit diagram, mechanical switch operation, external features and body drawings, component list, materials of construction, and intellectual property information. All information obtained from this laboratory must be recorded in your laboratory notebook in pen and the yellow sheet submitted at the end of the laboratory.

Format of Written Project

Submit one report per team. Reports must be printed and stapled in the upper left-hand corner and have 2.5 cm margins on all sides. The type font must be 12 points. The line spacing should be double-spaced. Each page should be numbered.

For help on report writing refer to the chapters "**Representations of Technical Information**" and "**The logical structure of Technical Reports, Section by Section**" in the course text.

The written project must contain the following:

1. A letter of transmittal addressed to your section professor stating the report title, what is in the report and why you are submitting it.
2. Cover Sheet - Use a descriptive title (give the brand and model) include team names, submittal date, and course and instructor name.
3. The body of the report, containing the following sections (see "**The logical structure of Technical Reports, Section by Section**" in the course text for detailed descriptions):

Abstract

Introduction

Methods and Materials - this is called "the procedural section" in your course text.

Results - Include appropriate tables (e.g., specifications, parts list) and figures (e.g., drawings) after their first mention in the text. This should cover the following:

- i) Form of Maglite: For example: What does it look like? Is it ergonomic? What is it made of? Include a parts list.
- ii) Function of Maglite: Describe how it works. Describe how it is constructed. Incorporate material, mechanical, electrical, and assembly factors into your discussion.
- iii) Intellectual Property of Maglite: Describe any patents on the product, including subcomponents. Use <http://www.delphion.com/> (you'll need to open a

"free basic registration" account), <http://www.uspto.gov/>, or other patent sites. When do the patents run out?

iv) Description of another small flashlight. Follow the general format used for the Maglite (Form/Function/Intellectual Property), but with less detail.

Discussion - It should cover the following:

- i) Summary of the desirable characteristics of the Maglite.
- ii) Comparison of Maglite and another small flashlight. How are they similar? How are they different? Which is best? Are they both designed to fulfill the same function?
- iii) Proposal to make a flashlight competitive to the Maglite. What desirable characteristics does a competitive flashlight need to have? Will there be problems with patents?

The discussion section is based only on information presented in previous sections, with the exception of the material on the proposed new flashlight.

Drawings - Include drawings in the Results sections (and the Discussion section if you want to include a drawing of the proposed flashlight). See the "Graphics" chapter of your course text (also called "Appendix C") for help on making engineering drawings. There should be at least a full page of drawings, drawn using AutoCAD, SolidWorks, or a similar drawing program. Mechanical Engineering students should learn SolidWorks; Civil Engineering students should learn AutoCAD. There is a very good online AutoCAD tutorial at:

<http://www2.ncsu.edu:8010/unity/lockers/project/graphicscourse/gc/acadtut/acadtut2000/acadtut-home.html>

Each drawing should be given a title (*e.g.*, Figure 1: Body of Maglite Flashlight). Figures should be referred in the Body of the Report (*e.g.*, Figure 1). **If a figure is not referenced in the body, it doesn't belong in the report!**

Drawings include:

- i) Dimensioned drawings of parts, including an exploded view diagram.
- ii) Electrical circuit diagram showing all pertinent parts.
- iii) Mechanical/Electrical switch operation.