

CEE 08 383 – Steel Frames

Exam 1

February 21, 2008

1. Determine the tensile capacity (ΦR_n) of the steel angle section below assuming block rupture is the controlling failure mode. Assume $\frac{3}{4}$ " diameter bolts. (15 points)

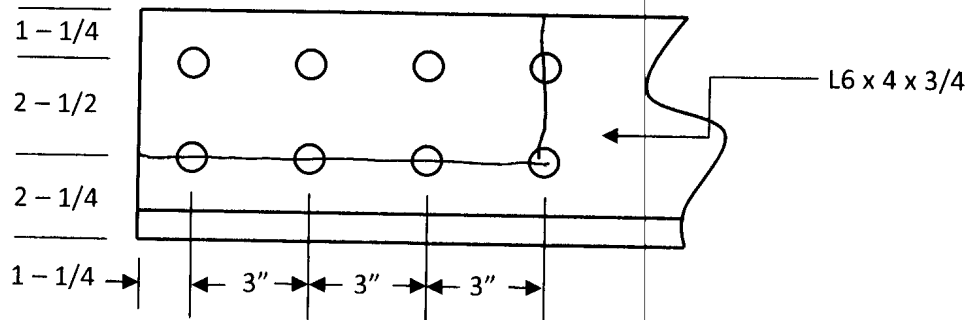

$$R_n = .6 F_u A_{nv} + U_{bs} F_u A_{nt} \quad \text{OR} \quad .6 F_y A_{gv} + U_{bs} F_u A_{nt}$$

$$A_{nt} = \frac{3}{4} (3.75) - \frac{1}{2} \left(\frac{3}{4} + \frac{1}{8} \right) \left(\frac{3}{4} \right) = 1.83 \text{ in}^2$$

$$A_{gv} = 10.25 \left(\frac{3}{4} \right) = 7.69 \text{ in}^2$$

$$A_{nv} = 7.69 \text{ in}^2 - \frac{3}{2} \left(\frac{3}{4} + \frac{1}{8} \right) \left(\frac{3}{4} \right) = 5.39 \text{ in}^2$$

$$.6 F_u A_{nv} = .6 (58 \text{ KSI}) (5.39 \text{ in}^2) = 187.6 \text{ K}$$

$$.6 F_y A_{gv} = .6 (36 \text{ KSI}) (7.69 \text{ in}^2) = 166.1 \text{ K}$$

$$R_n = 166.1 \text{ K} + 1.0 (58 \text{ KSI}) (1.83 \text{ in}^2) = 272.2 \text{ K}$$

$$\Phi R_n = .75 (272.2 \text{ K}) = 204 \text{ K}$$

2. Determine the net tensile area along the indicated failure path for the plate below. (15 points)

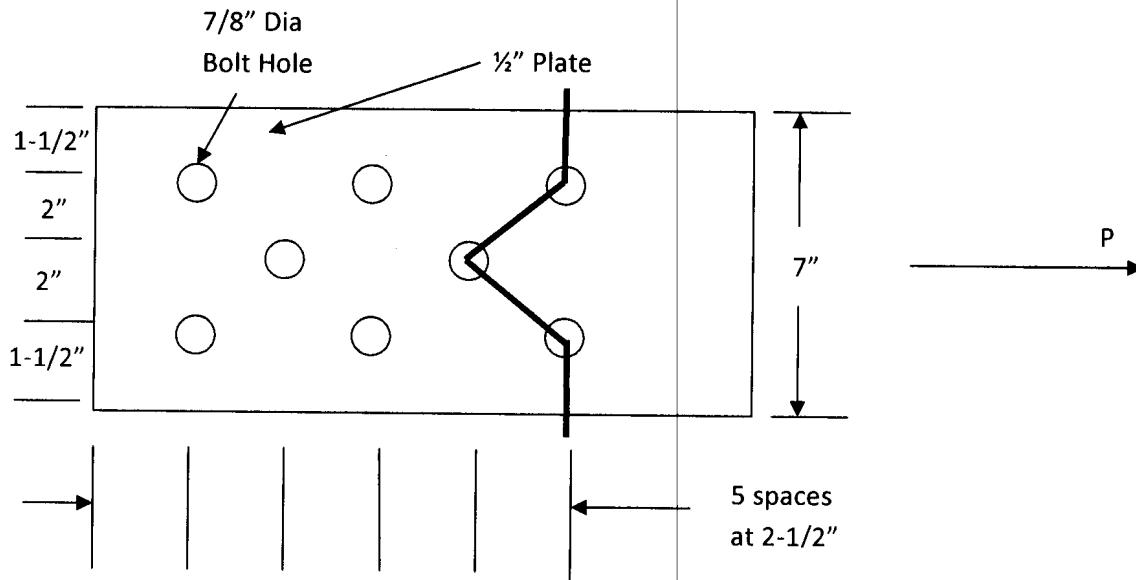

$$\text{NET WIDTH} = 7" - 3\left(\frac{7}{8}" + \frac{1}{16}"\right) + \frac{2\left(2\frac{1}{2}\right)^2}{4(2)} = 5.75"$$

$$A_n = 5.75" \left(\frac{1}{2}\right) = 2.875 \text{ in}^2$$

3. Two channels are placed back-to-back as shown below. Determine the tensile capacity based on failure of the gross or effective areas only. Assume $\frac{3}{4}$ " diameter bolts are used for the connection. (20 points)

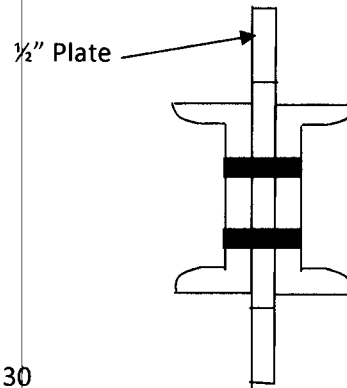
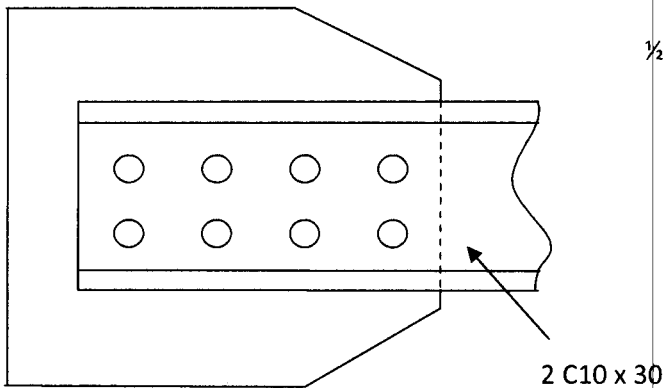

$$A_g = 8.81 \text{ in}^2$$

$$= t_w = .673"$$

$$\bar{x} = .649"$$

$$\phi F_y A_g = .9(36 \text{ ksi})(8.81 \text{ in}^2) = 284.4 \text{ k} \times 2 = 571 \text{ k} \quad \leftarrow \text{CONTROLS}$$

$$A_n = [8.81 \text{ in}^2 - .673" \left(\frac{7}{8} \right) (2)] \times 2 = 15.26 \text{ in}^2$$

$$\bar{x} = 1 - \frac{.649"}{9"} = .928$$

$$A_e = .928(15.26 \text{ in}^2) = 14.16 \text{ in}^2$$

$$\phi A_e F_u = .75(14.16 \text{ in}^2)(58 \text{ ksi}) = 616 \text{ k}$$

4. Double angles are to be used as a tension only brace. The angles are connected with a $\frac{1}{2}$ " plate between them. Select appropriate angles to support a service load consisting of dead load of 75 kips, live load of 100 kips, and a wind load of 65 kips. Consider the slenderness recommendations in your design (brace length is 25'). You may assume that two lines of $\frac{3}{4}$ " diameter bolts are used and block shear rupture is not a controlling failure mode. (15 points)

$$1.2(75) + 1.6(100) = 250 \text{ k} \leftarrow \text{CONTROLLING CASE}$$

$$1.2(75) + .8(65) = 142 \text{ k}$$

$$1.2(75) + 1.6(65) + .5(100) = 244 \text{ k}$$

TRY $2L5 \times 3\frac{1}{2} \times \frac{1}{2}$ w/ $A_g = 8.01 \text{ in}^2$

$$A_n = 8.01 \text{ in}^2 - 4\left(\frac{7}{8}\right)\left(\frac{1}{2}\right) = 6.25 \text{ in}^2$$

IF $U = 0.8$ $A_e = 5 \text{ in}^2$ AND SECTION WILL FAIL THE RUPTURE CHECK

GO TO NEXT STEP LARGER OR TO $2L5 \times 5 \times \frac{7}{8}$ & SECTION IS FINE

FOR SINGLE ANGLE

$$\frac{25'(12"/ft)}{1.983} = 305$$

BARELY OVER LIMIT
SO AS DOUBLE ANGLE IT
IS FINE.

5. A floor plan is shown below. Assuming that dead load on each floor is 65 psf and column B1 supports the load from 10 stories. Determine the live load (per floor) that can be applied. The section column under consideration is 36' long, may be considered pinned at the top and fixed at the base, and has additional weak axis bracing 16' and 26' above the base of the column. You do not need to employ live load reduction. The column is a W12 x 65 A992 section. (20 points)

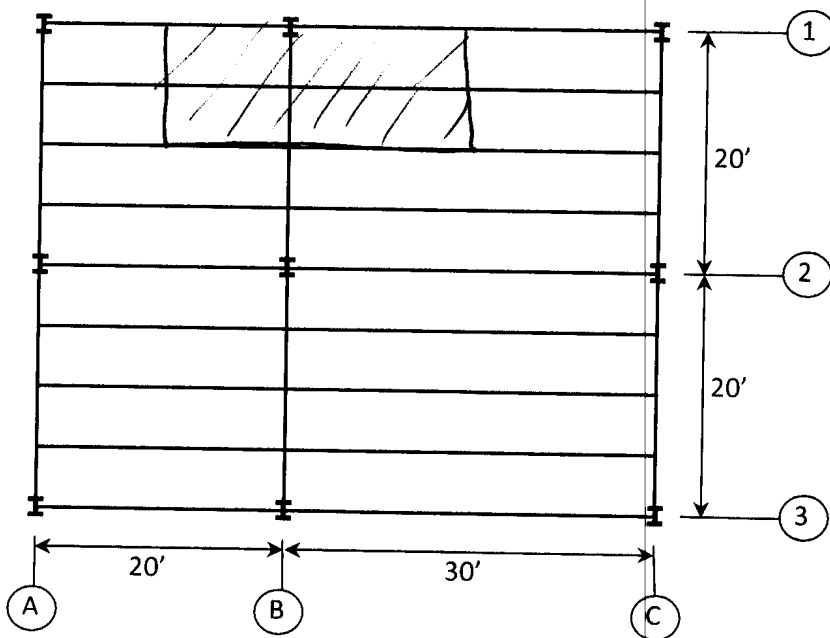

$$\begin{aligned}
 \text{LOADED AREA} &= 16' \times 25' \\
 &= 250 \text{ ft}^2 \\
 &\times 65 \text{ psf} \\
 &\times 10 \text{ STORES} \\
 \hline
 &162.5 \text{ k (DEAD)}
 \end{aligned}$$

$$(KL)_x = .8(36') = 28.8' \rightarrow \frac{28.8}{1.75} = 16.46' \leftarrow \text{CONTROLS}$$

$$(KL)_y = .8(16') = 12.8'$$

$$(KL)_z = 1.0(10') = 10'$$

$$\text{From PG 4-17 } \phi P_n = 627 \text{ k}$$

$$627 \text{ k} = 1.2(162.5 \text{ k}) + 1.6 P_L \rightarrow P_L = 270 \text{ k}$$

$$\frac{270 \text{ k}}{10} = 27 \text{ k} \div 250 \text{ ft}^2 = 108 \text{ lb/ft}^2$$

6. Select the lightest W12 section to support a service dead load of 400 kips and service live load of 575 kips. The structure is fixed at the base in both directions; pinned at the top in the weak direction; and free to sway and rotate at the top in the strong direction. The length of the section is 14'. (15 points)

$$1.2(400) + 1.6(575) = 1400 \text{ k}$$

$$(K L)_x = 2.1(14') = 29.4'$$

$$(K L)_y = .8(14') = 11.2'$$

CONVERT STRONG TO WEAK AXIS

$$\frac{(K L)_x}{C_M} = \frac{29.4'}{1.77} = 16.6'$$

SELECT A W12 X 152