METABOLISM

By: Rowan Students Rachel Specht, Johanna Kline, and Diana Russo
And Dr. Stephanie Farrell

OBJECTIVES

1. Determine the rate of energy expenditure at rest and during exercise.
2. Determine calories burned from fat and from carbohydrates.
3. Correlate basal metabolic rate with surface area.
4. Investigate engineering principles such as heat of reaction, mass and energy balances, and the First Law of Thermodynamics
5. Determine the mechanical efficiency of human body.
6. Record food energy consumption for one day and compare with energy expenditure.

INTRODUCTION

Your body uses energy constantly for all activities from thinking to strenuous exercise. In fact, the use of energy to accomplish external work such as walking, running, or lifting, represents only a small portion of the total energy use of the body. Most of the energy needed by the body is used to maintain the skeletal muscles (25%), the heart (25%), the brain (19%), and other organs. Your body obtains this energy from the food you eat, which is burned in a reaction with oxygen by the cells to produce energy. These reactions, treated as a system of synthesizing molecules and of breaking down molecules, are known as metabolism.

In this lab experiment, you will calculate the rate at which your body uses energy, both at rest and during exercise. You will use stoichiometry, heats of reaction, energy balances, and thermodynamics to perform work and energy calculations.

Heat of reaction is the energy released when a chemical reaction occurs (at constant pressure and a defined temperature). Consider the reaction below, in which glucose (a sugar) is burned with oxygen to produce carbon dioxide and water. The heat of reaction (ΔH_r) is 673 kcal per mole glucose[1]; in other words, reaction releases 673 kcal of energy per mole of glucose burned.

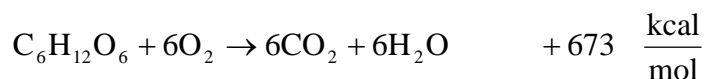

The reaction above also provides a relationship between the amount of oxygen used and the amount of energy produced by burning glucose. Since the oxygen for this reaction is obtained

through respiration, we can measure the amount of oxygen used through gas exchange testing as we did in the respiration experiment. We will use this information to determine the body's rate of Energy Expenditure (EE), which is the same as the rate at which energy is produced by burning food. This energy is either used to do external work (e.g., lifting a weight), or it is used for internal maintenance and eventually lost as heat.

In this lab you will use measurements of oxygen consumption and carbon dioxide production to determine the rate of energy expenditure (EE) at rest and during exercise. You will also be able to determine how much of that energy is produced by burning carbohydrates, and how much is produced by burning fats. You will compare the rate of Energy Expenditure to the rate at which you can perform mechanical work (exercise), which will reveal the *efficiency* of the human machine.

By recording the energy value of the food you consume in one day, you will be able to compare your rate of energy consumption with your rate of energy expenditure.

BACKGROUND

Basal Metabolic Rate (BMR)

The basal metabolic rate (BMR, kcal/hr) is the rate of energy expenditure for a person at rest. This is equal to about 60 to 70 percent of daily energy used. BMR is the total energy your body requires for normal bodily functions such as inhaling and exhaling air, digesting food, making new blood cells, and operating the organs. In other words, your BMR is all the energy used for the basic processes of life itself.

When energy is expended, heat is also produced. (This is why you feel hot when you do strenuous exercise). This heat must be released from the body (e.g., from your skin by perspiration), in order to maintain a normal body temperature. In the late 1800s, it was observed that the energy metabolism at rest is related to the surface area (SA, m²) of the body. (This makes sense, since most of our body heat is released from the body's surface). This was illustrated in an experiment in which the resting BMR of a dog and a man was determined during a 24-hour period. As expected, the total amount of heat generated by the larger man was about 200% greater than that generated by a dog. A series of experiments using different mammals (hen, rabbit, dog, man, pig, and cow) revealed that the ratio of BMR to SA is relatively constant.

This ratio $\left(\frac{(BMR)}{(SA)}, \frac{kcal}{m^2 h} \right)$ is a function of age (Y, in years) and gender (Wasserman Correlation, Medgraphics):

Male

$$\begin{aligned} \frac{(BMR)}{(SA)} = & \left[54.79 \frac{\text{kcal}}{\text{m}^2 \cdot \text{h}} \right] - \left[1.303 \frac{\text{kcal}}{\text{m}^2 \cdot \text{h} \cdot \text{yr}} \right] * Y + \left[0.0294 \frac{\text{kcal}}{\text{m}^2 \cdot \text{h} \cdot \text{yr}^2} \right] * Y^2 \\ & - \left[0.0001228 \frac{\text{kcal}}{\text{m}^2 \cdot \text{h} \cdot \text{yr}^3} \right] * Y^3 - \left[3.3558 * 10^{-6} \frac{\text{kcal}}{\text{m}^2 \cdot \text{h} \cdot \text{yr}^4} \right] * Y^4 \\ & + \left[2.903 * 10^{-8} \frac{\text{kcal}}{\text{m}^2 \cdot \text{h} \cdot \text{yr}^5} \right] * Y^5 \end{aligned} \quad (1)$$

Female:

$$\begin{aligned} \frac{BMR}{SA} = & \left[55.73 \frac{\text{kcal}}{\text{m}^2 \cdot \text{h}} \right] - \left[1.757 \frac{\text{kcal}}{\text{m}^2 \cdot \text{h} \cdot \text{yr}} \right] * Y + \left[0.0414 \frac{\text{kcal}}{\text{m}^2 \cdot \text{h} \cdot \text{yr}^2} \right] * Y^2 \\ & + \left[5.216 * 10^{-6} \frac{\text{kcal}}{\text{m}^2 \cdot \text{h} \cdot \text{yr}^3} \right] * Y^3 - \left[1 * 10^{-5} \frac{\text{kcal}}{\text{m}^2 \cdot \text{h} \cdot \text{yr}^4} \right] * Y^4 \\ & + \left[7.979 * 10^{-8} \frac{\text{kcal}}{\text{m}^2 \cdot \text{h} \cdot \text{yr}^5} \right] * Y^5 \end{aligned} \quad (2)$$

Surface Area can be found from the following correlation which relates SA to mass and height [2]:

$$SA = \left[0.202 \frac{\text{m}^{1.275}}{\text{kg}^{0.425}} \right] * m^{0.425} * h^{0.725} \quad (3)$$

where SA is in units of (m²), *m* is mass in kg and *h* is height in meters.

Foods used to obtain energy

Carbohydrates

Almost all of our energy needs come from carbohydrates and fats. (Proteins, another type of food, are used for other purposes and is not used to meet our energy needs). Glucose (a sugar) is a typical carbohydrate, and burned according to the reaction:



Fats

Fats are another class of food that the body uses to obtain energy. Palmitic acid, a typical fatty acid, is burned according to the reaction



Now compare the two reactions. Notice that to burn one mole of glucose, 6 moles of oxygen are used and 6 moles of carbon dioxide are produced. For palmitic acid, 23 moles of oxygen are required to burn one mole of palmitic acid! Much more oxygen is required to burn a fat. Now look at the energy released (the heat of reaction): 1086 kcal for every mole of palmitic acid that is burned, but only 673 kcal per mole of glucose. Fats have a very high energy value! In general, much more oxygen is consumed to burn fats, and fats have a much higher energy value than carbohydrates.

Respiratory Exchange Ratio

Notice that in the reaction for burning glucose, Equation 4, the ratio of the number of moles of O₂ to CO₂ is 1:1. This ratio is called the Respiratory Exchange Ratio (RER).

$$RER = \frac{\text{\# moles CO}_2 \text{ produced}}{\text{\# moles O}_2 \text{ consumed}} \quad (6)$$

The oxygen for this reaction is obtained directly through respiration. The carbon dioxide produced by the reaction is eliminated through respiration. Therefore the number of moles of O₂ and CO₂ can be obtained through respiration measurements. RER can be calculated from these measurements:

$$RER = \frac{\dot{V}CO_2}{\dot{V}O_2} = \frac{\dot{n}_{CO_2}}{\dot{n}_{O_2}} \quad (7)$$

Now look at the reaction for oxidation of fat shown in Equation 5. Notice that the ratio of the number of moles of O₂ to CO₂ is 16/23, or 0.696.

There are many carbohydrates besides glucose, and many fats besides palmitic acid. But these are very typical examples of carbohydrates and fats. After studying mixtures of carbohydrates, and mixtures of fats, the following average RER values have been found:

	Carbohydrate	Fat
RER	1.0	0.707

Since carbohydrates and fats are burned at the same time, the measured RER value is usually somewhere between 1.0 (for pure carbohydrates) and 0.707 (for pure fat). The RER is a convenient indicator for the proportion of carbohydrates and fats being burned.

Energy Expenditure and RER

Consider again the reaction for a glucose, a typical carbohydrate (Equation 4). There is a relationship between the moles of oxygen consumed, the moles of carbon dioxide produced, and the energy released. The RER, or molar ratio of carbon dioxide to oxygen, is 1.0, and the energy released is 673 kcal for every 6 moles of oxygen used.

We can generalize these relationships for average carbohydrates, and for also average fats:

	Carbohydrate	Fat
RER	1.0	0.707
Energy released per mole of oxygen used (kcal/mol)	113.0	104.9
Energy released per liter of oxygen used (kcal/L)	5.047	4.686

(At Standard Temperature and Pressure, 0°C and 760 mm Hg)

The measured RER value is usually between 0.707 and 1.0, because we are usually burning a mixture of fats and carbohydrates from our diet. Since the RER value is an indicator of the proportions of fats and carbohydrates being burned from a mixed diet, we can expand the table above to include a mixed diet.

Table 1. Energy Released as a function of RER, for a mixed diet. Volumes measured at STP (0°C, 760 mm Hg)

Nonprotein RER	Energy Released (kcal/L oxygen consumed) EE/VO₂	Energy Released (kcal/mole O₂) EE/nO₂	% of energy from carbohydrates	% of energy from fat
0.707	4.686	104.9	0.0	100
0.75	4.739	101.9	15.6	84.4
0.80	4.801	107.5	33.4	66.6
0.85	4.862	108.9	50.7	49.3
0.9	4.924	110.3	67.5	32.5
0.95	4.985	111.7	84.0	16.0
1	5.047	113.0	100	0.0

* From McArdle [3], p. 153.

The information in Table 1 can also be expressed as an equation.

$$\frac{EE}{\dot{V}O_2} = \left(1.23 \frac{\text{kcal}}{\text{L}} \right) RER + 3.8156 \frac{\text{kcal}}{\text{L}} \quad (8)$$

In this Equation 8, $\dot{V}O_2$ is evaluated at 0°C and 760 mm Hg (STPD). $\dot{V}O_2$ is known from respiratory measurements. If we find $EE/\dot{V}O_2$ from Equation 8, we can calculate the rate of energy expenditure (EE):

$$EE = \dot{V}O_2 \left(\frac{EE}{\dot{V}O_2} \right) \quad (9)$$

Mechanical Efficiency

The human body can be analyzed as a machine in terms of a mechanical energy balance. The percent efficiency of a machine or a human can be calculated as:

$$\eta = \frac{\text{work done}}{\text{energy used}} * 100 \quad (10)$$

Work is measured in units of energy (e.g., kcal or J). Bicycle riding is one of the most efficient activities, and the mechanical efficiency is still only about 20%! This means that for every 100 kcal burned during bicycle riding, only 20 kcal of mechanical work is actually accomplished. The efficiency can also be expressed in terms of rates: the rate of work done / the rate of energy expended just for cycling (EE-REE):

$$\eta = \frac{\text{rate of work done}}{EE - REE} * 100 = \frac{\text{power}}{EE - REE} * 100 \quad (11)$$

To calculate efficiency, we need to measure both the rate of work done (the power), the energy expenditure (EE) and the resting energy expenditure (REE).

Power is the *rate* at which work is done. A machine called an ergometer is used to measure power. We will use a bicycle ergometer to measure the mechanical power of the human body. The power measurement is given in units of Watts. A Watt is equivalent to one Joule per second, and it is also equivalent to 0.0134 kcal/min.

Power: 1 W = 1 J/s = 0.0134 kcal/min

Work: 1 J = 2.39 x 10⁻⁴ kcal

Energy Expended (EE) is the rate of total energy expenditure during bicycling. This is calculated from respiratory measurements of $\dot{V}O_2$ and RER, using Equations 8 and 9.

Note: A calorie is a unit of measure from energy. One calorie is equal to the amount of energy needed to raise 1g of water by 1°C. The calories that are used to measure food are actually kilocalorie, which are also referred to as Calories (with the capital C).

First Law of Thermodynamics

If more food is consumed than is burned for energy, the excess is stored in the body (for instance, as body fat). This is an example of the *First Law of Thermodynamics*, which when applied to the body would be expressed as:

$$\begin{array}{rclcl} \Delta U & = & Q & - & W \\ \text{Change in stored energy} & = & \text{heat gained} & - & \text{work done} \\ \text{(in the body)} & & \text{(by the body)} & & \text{(by the body)} \end{array}$$

Energy can be stored as food (before it is burned for energy) or in the form of body fat. When work is done, heat is lost by the body (because the body is not completely efficient); the total of the work done and heat lost is the Energy Expenditure (EE). By applying the First Law of Thermodynamics, we can calculate the energy equivalent of body fat lost or gained in one day:

$$\begin{array}{rclcl} \text{Change in energy} & = & \text{energy consumed} & - & \text{daily energy} \\ \text{equivalent of body fat} & & & & \text{expenditure} \end{array}$$

In other words, the First Law of Thermodynamics tells us that if we consume more food calories than we expend in our daily activities, the excess will be stored as body fat.

EXPERIMENTAL PROCEDURE

1. Select one member from the group to control the computer and another to be the test subject. Each test subject will receive a pneumotach. Please **do not** share pneumotachs. The rest of the group members are responsible for recording the information and instructing the computer controller and the test subject as per the procedure.
2. Record the test subject's age, height (in), and weight (lbs) in a laboratory notebook.
3. Open the program named "Breeze".
4. Select **File, New, Patient**. --
5. Input the test subject's **last name, ID** (initials), **DOB** (date of birth), **Race, Sex**.
6. Select **Edit, Add Visit**.
7. Fill in the test subject's **height** (in inches, ex. 5'5"=65 inches) and **weight** (lbs).
8. Select the **GX** tab at the bottom of the screen. Ensure that the following options are set:
 - a. Choose Bike for the Scriptname
 - b. Clear all boxes for external devices
 - c. Choose freewheel 0 minutes and 15 W ramp exercise test
9. Make certain that the gas sample line (pink wire) is connected to the Cal/Port.
10. (Only if instructed by your professor...) Select **Zero Flow**, then **GX AutoCal**. Allow system to recalibrate.
11. The test subject should prepare the pneumotach (Figure 2) for testing.

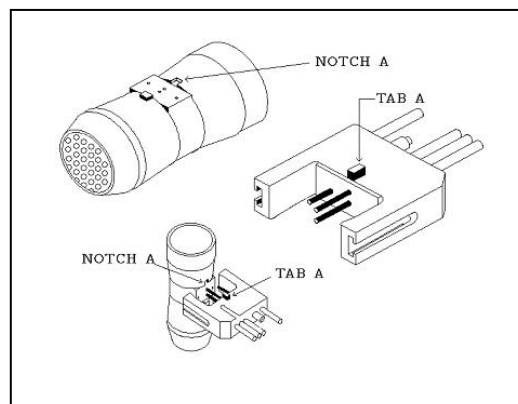

Figure 1. Pneumotach

- a. Inspect the pneumotach for any abnormalities or cracks.
- b. Place the pneumotach into the umbilical clip, aligning the clip tab with the notch in the pneumotach.

- c. Undo the gas sample line from the Cal/Port and insert it into the pneumotach. Ensure that the gas line (pink wire) can be seen in the pneumotach but is not touching the crossbars (Figure 3).

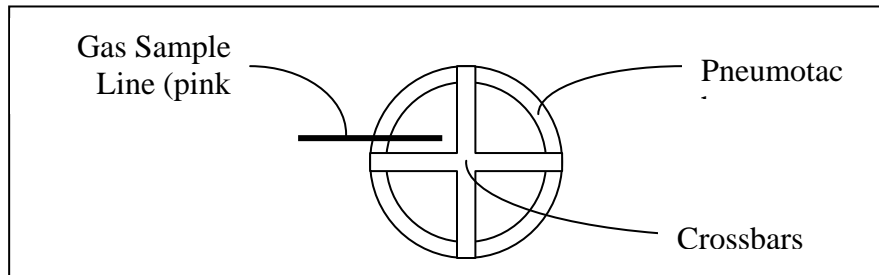

Figure 2. Correct placement of Sample line

- d. Insert pneumotach, grated side first, into saliva trap mouthpiece.
12. Test subject should sit on the bicycle and make certain that his/her feet are strapped in. For the at rest portion, the test subject should remain still. Position the pneumotach in mouth so that the sample line enters from the top of the pneumotach. Place the nose clips over the test subject's nose and continue to breathe normally.
13. Select the **BxB** tab at the bottom of the screen.
14. Select **Tools** and **PWave**. Verify that the compute program is accepting data.
15. Close the **PWave** box.
16. Click **Start** on the test pad to begin data collection. Allow data to be collected for two minutes while the test subject is at rest (time recorded on computer screen).

Observe the RER values. If you observe RER values above 1.0 after 2 minutes, ask your instructor for suggestions on how to proceed. Elevated RER values (under these test conditions) might indicate that the patient is not fully relaxed and breathing normally, which is very common. Usually it just takes a couple of minutes to relax and get RER values less than 1.0.
17. When two minutes have passed, select **Exercise** on computer screen. The test subject should now begin to pedal, maintaining the bicycle speed between 50-80 rpm (rpms can be determined from the face of the bicycle). While exercising, the pneumotach should be held steady in the mouth.
18. Continue data collection during exercise for two more minutes. When the time reaches 4 minutes on the screen, select **Stop**. The test subject can now remove the pneumotach and the nose clip and dismount the bicycle. (**Note: Group members should have paper towels ready for when the test subject has finished using the equipment.**)
19. To retrieve the data, select **Reports, Report Switchboard**, and click **OK** on the pop-up window.
20. Choose Freshman Clinic Report
21. Print out the report by selecting **Print Report** and close the Access window.
22. Place used pneumotachs in sink.

HOMEWORK

To be turned in on the due-date: (1) Lab notebook page, (2) calculations, (3) answers to follow-up questions and (4) one evaluation survey per team member. The calculations should be neatly written on engineering paper (show all steps and show units throughout your calculations). The answers to the follow-up questions should be typed.

Calculations

- 1) Estimate the expected basal metabolic rate for your test subject. (Recall that the basal metabolic rate is the rate of energy required just to maintain the basic life processes of the body). Follow the steps below.
 - a) Estimate the ratio of BMR/SA using Equation 1 (male) or Equation 2 (female).
 - b) Estimate the surface area using Equation 3.
 - c) Find BMR by multiplying $(\text{BMR}/\text{SA}) \cdot \text{SA}$.

Perform the following calculations on measurements taken immediately prior to the start of exercise, and during exercise (just before the end of the test).

- 2) Using values of VO_2 and VCO_2 , calculate your RER value using Equation 7. Compare this to the value calculated by the software.
- 3) Calculate the ratio EE/VO_2 using Equation 8.
- 4) Calculate the rate of energy expenditure using Equation 9.
- 5) Calculate the Mechanical Efficiency (%) during exercise, using Equation 11.

Follow-up Questions

1. How many 100 W light bulbs can your test subject light, assuming the power value is equal to the mechanical power of bicycling?
2. A kilowatt-hour (kWh) is a unit of energy that is commonly seen on household energy bills. A kilowatt-hour is the energy equivalent of 1 kilowatt of power for a time of one hour.

$$\text{Energy} = \text{Power} \cdot \text{time}$$

$$1 \text{ kWh} = 1 \text{ kW} \cdot 1 \text{ hr}$$

A typical residential energy cost is \$0.12 per kWh. If your test subject were to ride the bicycle ergometer for one year at the same power expended during the test, how what is the value of the energy he or she would produce?

3. In motion, the human body also uses energy very efficiently. For example, a person running a marathon 26 miles burns only about 2,600 kcal. Running is considered to burn 100 kcal per mile.

Bicycling at a rate of 15 miles per hour burns 0.049 kcal/min/pound [4]. The rate of energy expenditure in kcal/min can be determined by multiplying by body weight in pounds.

Like carbohydrates and fats, gasoline is a fuel that can be burned with oxygen to produce energy. A gallon of gasoline releases 31,000 kcal when it is burned. A reasonably efficient automobile can drive 30 miles on one gallon of gasoline.

How much energy (in kcal) would be consumed in traveling a distance of 10 miles by

- a. A typical runner
 - b. Your test subject cycling 15 miles per hour
 - c. A reasonably energy efficient automobile
4. One day this week record the food and drink that you consume and determine how many calories you consume in one day.
- a. Use food labels for packaged food, and refer to calorie tables (the Metabolism Module website has links to calorie tables, including some for fast foods).
 - b. Estimate your energy expenditure for one day. For a normally active person, the Basal Metabolic Rate is about 60-75% of the total daily energy expenditure. Choosing an intermediate value of 70%,

$$(\text{total daily energy expenditure}) = \frac{\text{BMR}}{0.7}$$

- c. Use the first Law of Thermodynamics to determine your net gain or loss of body fat for the day.

$$\text{Change in energy equivalent of body fat} = \text{energy consumed} - \text{daily energy expenditure}$$

REFERENCES

1 Cooney, D., Biomedical Engineering Principles, Marcel Dekker, Inc. New York, 1976.

2 Cameron, J., J. Skofronick, and R. Grant, Physics of the Body, Medical Physics Publishing, Madison, WI, 1992.

3 McArdle, W.D., F.I. Katch, and V.L. Katch. Exercise Physiology: Energy, Nutrition, and Human Performance. 4th edition, Lea and Febiger, Philadelphia, PA: 1996.

4 How Stuff Works Website <http://www.howstuffworks.com/questions527.htm>, 2/3/2002.